

High Voltage Component Production Testing with Two Model 2410 SourceMeter® Units

Introduction

Various production test applications require the use of a higher test voltage than a single Model 2410 High Voltage SourceMeter can supply (1100V). Connecting two of these instruments in series makes it possible to supply twice the rated voltage of one unit (for a total of 2200V) at the same current (up to 20mA). This technique is useful for any high voltage test application that requires precision source and measurement capabilities. Higher test voltages are especially useful for production testing of diodes and other high voltage components. Like the rest of the Series 2400 SourceMeter family, the Model 2410 combines the capabilities of several instruments in a single unit, including a digital multimeter (DMM), and precision readback voltage and current sources.

If a test procedure requires only one of a number of measurements to be made with a 1.1–2.2kV test voltage, the system configuration outlined in **Figure 1** can accomplish this easily. However, this configuration can also perform the other measurements commonly needed to characterize high voltage components. Best of all, the tests can be done either through the front panel controls or via the IEEE-488 or RS-232 bus, without the need to switch connections between the instruments and the device under test (DUT).

Test Descriptions

High voltage component testing applications include characterizing diodes or varistors, measuring the insulation resistance of connectors, etc. When characterizing diodes, the tests usually involved include the Reverse Breakdown Test (V_R), Forward Voltage Test (V_F), and the Leakage Current Test (I_R). In this instance, the high voltage capability is needed only for the V_R test, but the other tests can also be completed in software without the need to change connections. For other high voltage components, such as varistors, the system in **Figure 1** can perform the Nominal Voltage Test, DC Standby Current Tests, Non-Linear Exponent (or Alpha) Test, and, most importantly, the Second Breakdown Voltage Test. Insulation resistance and high value resistor testing often require high test voltages, so these applications would also benefit from this test configuration. The applications aren't limited to those mentioned; this system is suitable for any component that requires a test voltage up to 2200V.

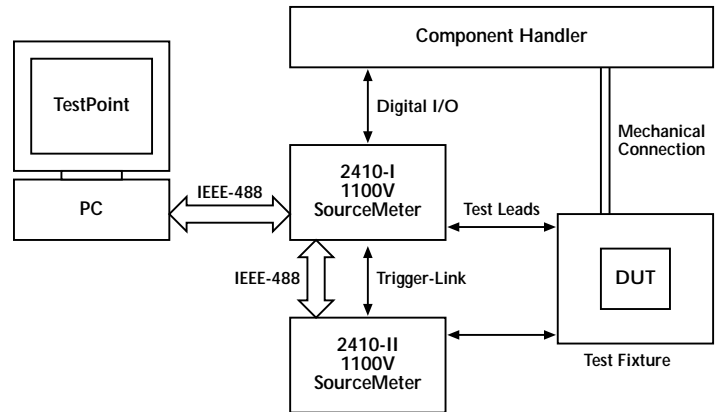

Figure 1. System block diagram.

Test System Configuration

The theory behind the operation of this system in both two- and four-wire sense modes is that, for the V_F and I_R tests of a diode, the first instrument (Model 2410-I) is configured to perform these tests by itself. The second unit (Model 2410-II) is configured as a voltage source with a value of zero, which models the unit after a battery with very low internal impedance. Ideally, the Model 2410-II does not affect the measurement made by the Model 2410-I. In a sense, for the V_F and I_R tests, the Model 2410-I performs the low voltage and current tests with a shunt resistor in series with it. The effect of equivalent shunt resistance of an active source is discussed in the section entitled “Typical Sources of Error.”

For the V_R (>1100V) test, it is first necessary to determine the compliance voltage at which the diode should be verified. Although it may be possible to configure two Model 2410s as voltage sources in series, this application requires a current source with high voltage compliance. Pick a convenient split point in this voltage value so that the total voltage is divided between the two units without exceeding the operating limit of either one. For example, for a 1700V test, the Model 2410-I might take 1100V while the Model 2410-II handles 600V of the total output to the test circuit. If the desired test current is 10mA, 2410-I would be set as a current source of 10mA with an 1100V compliance and 2410-II would be set as a voltage source of 600V with a 10mA compliance. It does not matter what the voltage on each unit is, but both units should be on the same voltage source range.

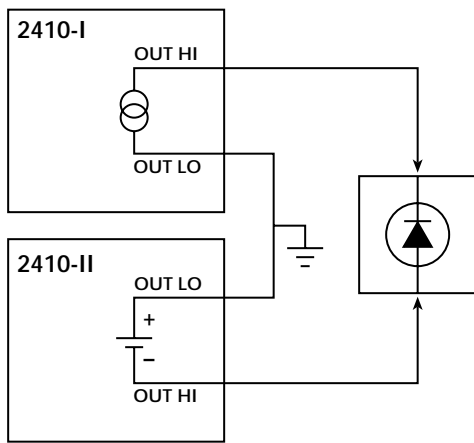

Figure 2a. Two-Wire Connection

As shown in **Figure 2**, one unit is set as a current source and the other as a voltage source, which results in the system behaving like a single current source. Throughout the test sequence, the Model 2410-II is set to a voltage source with low internal resistance. This allows current to flow through this unit and provide a low impedance terminal to the low of the DUT. The current source's HI terminal provides the high impedance connection to the circuit. When configured properly, the two units act as a single instrument, sourcing a voltage to the DUT and reading back both the current and the source value. From the read-back information, the Model 2410-I has the capability to do pass/fail analysis and interface with the user or with a component handler. For more information on this capability, refer to the section entitled, "Pass/Fail Analysis."

Even though the Model 2410-II looks like a shunt, it still has a small voltage drop across it that is roughly equal to the instrument's offset. On the 2V range, the instrument has about $300\mu\text{V}$ of noise, which can be an issue when performing a forward voltage test by adding to the error of the measurement. If the magnitude of this offset is insignificant, the 2-wire scheme (**Figure 2a**) will work and involves less wiring. However, if the offset is significant, the 4-wire approach (**Figure 2b**) is preferred to avoid adding the offset to the result.

In this system configuration, it is critical to connect the high impedance terminal of the instrument to the high impedance of the test circuit and the low impedance terminal of the instrument to the low impedance of the test circuit. If the system is not configured in this way, minimal current will be generated with respect to the common mode. Refer to Keithley's *Low Level Measurements* for a more detailed discussion of these system connection issues.

Operation

Refer to the trigger model (**Figure 3**), where it is important to note the Source-Delay-Measure (SDM) cycle. In this cycle, the source value is applied, a user-specified delay allows the

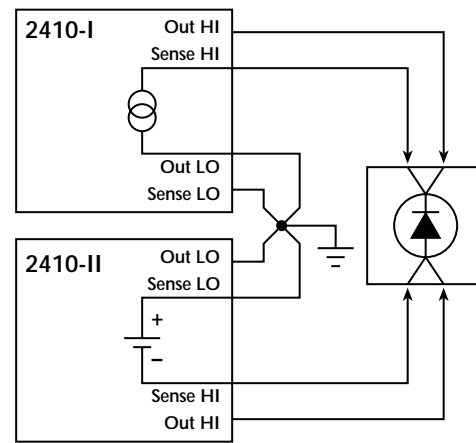

Figure 2b. Four-Wire Connection

circuit to stabilize, then a measurement is taken. This entire system is made feasible by the fact that each of these steps can be triggered externally, and an output trigger can be sent after each step is completed. When configuring the SourceMeter instruments to act simultaneously, it is important to have them trigger off of each other in order to apply potential to the circuit at virtually the same time, which is acceptable when testing passive components. **Figure 3** details the process of synchronizing the units, including the SCPI commands needed to control the various triggers over the bus. If both instruments have Firmware Revision C10 or later, an automated system can be created by using the instruments' Trigger-Link feature. If not, the instruments must be controlled independently over the bus.

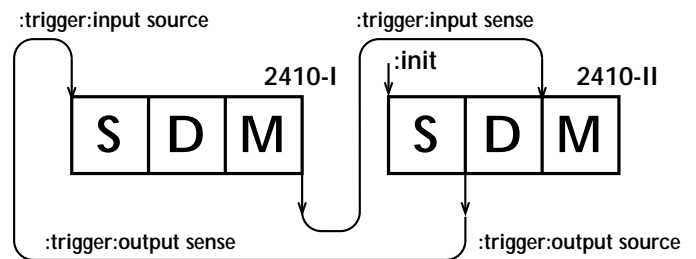

Figure 3. Synchronization of Model 2410 Trigger Models

The following algorithm describes the synchronization shown in **Figure 3** for one source-measure cycle.

1. 2410-II is initialized to the SDM segment of the trigger model by sending `:INIT` over the bus and supplying the necessary triggers.
2. 2410-II starts sourcing voltage and sends an output trigger once completed.
3. After the 2410-II outputs the trigger, it completes the delay portion and waits for a trigger to start measuring.
4. 2410-I receives the initial pulse from 2410-II and starts sourcing a current with a high compliance. The addition of

the compliance value of 2410-I and the source value of 2410-II give the desired high test voltage.

5. With both units applying a voltage to the circuit, 2410-I completes the entire SDM cycle and sends an output trigger after the measure portion.
6. 2410-II receives this trigger and takes its measurement.
7. Both SourceMeter instruments return to the idle state of the trigger model.

Pass/Fail Analysis

The pass/fail and handler interface capabilities of the Model 2410 can be enabled once the test system is configured and running. Model 2410-I is configured to output a known current. Model 2410-II looks like a battery that will always output the programmed voltage, and with its low internal resistance, it will follow the first Model 2410 and output the same current. The remaining level that is unknown is the voltage level in Model 2410-I.

The pass/fail criteria is based on the level of voltage in Model 2410-I when testing a component. Therefore, only one unit actually controls the test. Having the data from only one unit being of consequence to the test simplifies the classification of parts and handler interfacing. Of the four possible voltage and current levels in the two units, only one is unknown. This unknown voltage is used for pass/fail analysis of the DUT. The result of the pass/fail decision is communicated by the instrument via the front panel display or to the digital I/O for handler interfacing.

Typical Sources of Error

Offset

Certain offsets are associated with the various source ranges in the Model 2410. These include the $600\mu\text{V}$ offset on the 200mV range and the 600pA offset on the $1\mu\text{A}$ range. More information on these offsets is available in the instrument's source specifications. This offset introduces a quantifiable uncertainty into a measurement. All sources exhibit some degree of offset, which will introduce the uncertainty into a measurement. To minimize this uncertainty, it is possible to use the Series 2400 line's concurrent measurement (or readback) capability, which measures both the circuit response and the source value on the same measurement cycle.

To enable this capability over the bus, use this command sequence:

```
:SENSe:FUNCTION:CONCurrent ON
```

To display this using the front panel controls, press the Toggle button repeatedly, until the source function in use (voltage or current) is shown on the measurement display.

This ability to measure the source can reduce offset uncertainty by 50%, which implies only approximately $300\mu\text{V}$ offset on the 200mV range and 300pA on the $1\mu\text{A}$ range.

Noise

The use of high voltage in testing usually implies it is also necessary to measure low currents to determine large resistance values. There are many sources of error when dealing with very low currents. Errors in current-measurement instrumentation typically arise from extraneous currents flowing through various circuit elements as a result of triboelectric, piezoelectric, and electrochemical effects. For a more detailed description of these effects, refer to Keithley's *Low Level Measurements* handbook.

One source of error due to the way this system is configured arises from where the measurement is taken in the circuit. The Model 2410 that is programmed as a current source (Model 2410-I) measures the value of current it is sourcing internally. The measurement circuitry in this instrument senses the value that it has at the output terminal. Once the current flows out of Model 2410-I, the signal is susceptible to noise in the cabling, which cannot be detected by the Model 2410-I. Since the Model 2410-II is a voltage source, the current it measures has gone through the circuit and cabling and is measured as an input. This implies that the current it measures is the test current plus the added noise. The result is that unless guarding is used properly to eliminate noise from cables and other sources, the two instruments will display different currents in the circuit. Ideally, these two currents would be exactly the same. Even setting a higher integration rate inside the units will not always help eliminate the noise because integration works to eliminate periodic noise, which usually originates from the power line. Noise due to cables and connections is usually not periodic. Refer to the *Low Level Measurements* handbook for more information on the sources of noise in cables and how to prevent these noise sources from degrading measurement integrity.

Use of the cable guard feature of the Model 2410s and proper connection to the DUT can virtually eliminate these noise effects. The cable guard can be enabled over the bus by sending the command **:SYSTEM:GUARd CABLE** or over the front panel under the configure V-Source menu. **Figure 4** details connection to the DUT to reduce the effects of noise using this method. The amount and quality of cabling in this case is the most problematic, but it will offer the best system performance.

Equivalent Shunt Resistance (2-Wire)

It is important to remember that when the output of the Model 2410 is on and set to zero, a certain shunt resistance exists because the instrument simulates a battery with very low internal impedance. Even though the Model 2410 acts as a short, there is a certain resistance, and thus a corresponding voltage offset. This may not pose a problem with high volume low-precision parts if this offset is not significant to the final result. However, in applications that demand higher accuracy, it may be necessary to compensate for this offset in the data by subtracting

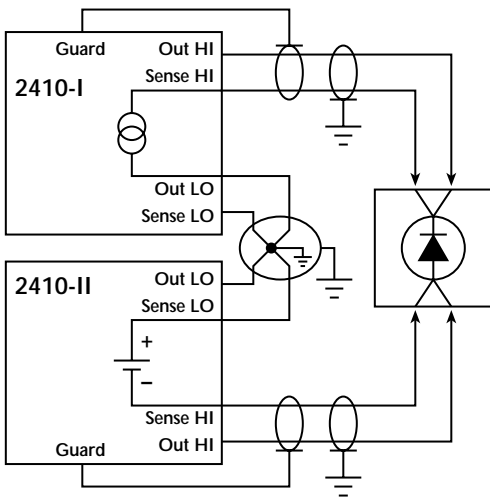

Figure 4. Shielding of the Test System to Reduce Noise Effects

the offset from the data. The offset would have to be fully characterized and would not necessarily change over time, so that, just by subtracting it from the data, it may be possible to get more accurate measurements.

This offset can be characterized using the two Model 2410s and a DMM. Set one of the units to output zero volts and turn the output on. Connect the other SourceMeter to the first unit by running a wire between the Output HI and the Output LO terminals. Output a small current into the first Model 2410 with the second unit. Connect the DMM in parallel with the unit that is sourcing the current and measure the voltage. The voltage displayed on the DMM is the offset associated with the Model 2410 with its source set to zero volts.

Typical values of equivalent shunt resistance for all ranges are about 150 mW. For the 1.1kV range on the Model 2410, the equivalent shunt resistance is approximately 400mΩ. The current flow and subsequent voltage drop across this resistance may be great enough to affect the measurement of the DUT. This effect of equivalent shunt resistance virtually disappears when utilizing the unit in 4-wire sense mode and we are left with just the specified offset of the instrument. Refer to **Figure 5** for the configuration to verify this offset.

Example Program

The example program Keithley has developed executes the Forward Voltage, Breakdown Voltage, and Leakage Current Tests on one RF-117 diode. At the end of the test, an output report is generated containing pass/fail status and the test voltages and currents. The detailed comments that accompany the program provide insight into the intricacies of configuring the Trigger Models of two Keithley Series 2400 instruments over the bus. Configuring the two units properly will ensure that the system operates much like a single instrument. A detailed description of the Trigger Model can be found in the Model 2410 User's Manual in the Remote Operation section.

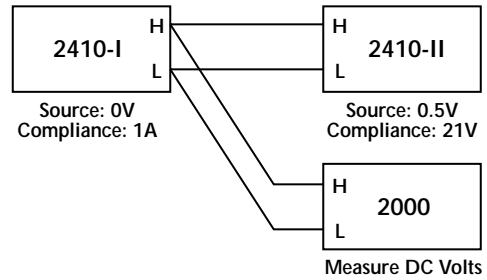

Figure 5. Verification of Offset in a Model 2410

To obtain a copy of the Example Program as a digital file, access Keithley's World Wide Web site, <<http://www.keithley.com>> or our ftp server <<ftp://ftp.keithley.com/pub/instr/SourceMeter/2kv.zip>>.

Equipment List

The following equipment is required to assemble the 2.2kV component verification system and run the listed program:

1. Two Keithley Model 2410 High-Voltage SourceMeter units
2. PC with KPC-488.2 Interface Card
3. Two Keithley Model 7007 IEEE-488 Interface Cables
4. Keithley Model 8501 Trigger Link Connector
5. Test leads to connect to device under test

Alternative Solutions

It would be possible to use either of the other members of the Series 2400 SourceMeter line. Two Model 2400 SourceMeter units could be used to create a 200V, 1A system, while two Model 2420s could be configured into a 120V, 3A system. Remember: when configuring a system as described in this application note, it is critical to use two units of the same model number, so that the rated power limits of one of the instruments are not exceeded.

Safety Note

When dealing with hazardous voltages, it is critical to insulate or install barriers to prevent user contact with live circuits. Failure to exercise these precautions could result in electric shock or death.

It is also important to ground the LO terminals of both SourceMeter units, as shown in **Figures 2** and **4**. If the DUT becomes grounded and the steps above are not followed carefully, the equipment could be damaged. Generally, when a device is shorted, measurements cannot be made, but when high voltages are involved, special care must be taken.

Please refer to the Model 2410 User's Manual for additional safety considerations.

For More Information

More in-depth information on the Model 2410 High Voltage SourceMeter and measurement techniques is available in the following Keithley publications:

- *Low Level Measurements*, 5th edition, 1998.
- Model 2410 SourceMeter User's Manual.
- Keithley Application Note 100, Low Current Measurements.

KEITHLEY



Keithley Instruments, Inc. • 28775 Aurora Road • Cleveland, Ohio 44139 • 440-248-0400 • Fax: 440-248-6168 • www.keithley.com

BELGIUM:	Keithley Instruments BV	Bergensesteenweg 709 • B-1600 Sint-Pieters-Leeuw • 32-2-363-00-40 • Fax: 32-2-363-00-64
CHINA:	Keithley Instruments China	Yuan Chen Xin Building, Room 705 • 12 Yumin Road, Dewai, Madian • Beijing 100029 • 8610-62022886 • Fax: 8610-62022892
FRANCE:	Keithley Instruments SARL	3 Allée des Garays • B.P. 60 • 91122 Palaiseau Cédex • 33-1-60-11-51-55 • Fax: 33-1-60-11-77-26
GERMANY:	Keithley Instruments GmbH	Landsberger Strasse 65 • D-82110 Germering, Munich • 49-89-8493070 • Fax: 49-89-84930759
GREAT BRITAIN:	Keithley Instruments, Ltd.	The Minster • 58 Portman Road • Reading, Berkshire RG30 1EA • 44-118-957-5666 • Fax: 44-118-959-6469
INDIA:	Keithley Instruments GmbH	Flat 2B, WILOCRISSA • 14, Rest House Crescent • Bangalore 560 001 • 91-80-509-1320/21 • Fax: 91-80-509-1322
ITALY:	Keithley Instruments SRL	Viale S. Gimignano 38 • 20146 Milano • 39-02-48303008 • Fax: 39-02-48302274
NETHERLANDS:	Keithley Instruments BV	Avelingen West 49 • 4202 MS Gorinchem • 31-(0)183-635333 • Fax: 31-(0)183-630821
SWITZERLAND:	Keithley Instruments SA	Kriesbachstrasse 4 • CH-8600 Dübendorf • 41-1-821-94-44 • Fax: 41-1-820-30-81
TAIWAN:	Keithley Instruments Taiwan	1 Fl. 85 Po Ai Street • Hsinchu, Taiwan, R.O.C. • 886-3572-9077 • Fax: 886-3572-9031